

Installation Guide *MagSpring®*

Version 1.4

CAUTION

MAGSPRING SLIDERS CONTAIN NEODYMIUM MAGNETS WHICH MAY DISTURB OR DAMAGE MAGNETIC DATA CARRIERS AND DELICATE ELECTRONIC EQUIPMENT LIKE PACEMAKERS, CELLPHONES, COMPUTERS OR WATCHES MERELY BY COMING CLOSE TO THEM.



DO NOT HEAT THE SLIDERS. THE MAGNETS WILL BE DESTROYED BY TEMPERATURE HIGHER THAN 80°C (180°F)



WHEN HANDLING SLIDERS BE AWARE THAT, DUE TO THE STRONG MAGNETIC ATTRACTION, INJURY FROM FINGERS BEING PINCHED BETWEEN THE SLIDER AND NEARBY STEEL PARTS IS A VERY REAL POSSIBILITY IF CAUTION IS NOT EXERCISED.



MAGSPRING SLIDERS 'SNAP' TO THEIR CENTER POSITION WHEN RELEASED, OR UPON POWER SHUTDOWN OF THE MACHINE THEY ARE INSTALLED ON. ACCORDINGLY, CARE MUST BE TAKEN TO GUARD AGAINST INJURY TO PEOPLE IN THE AREA WHERE THE MAGSPRINGS ARE BEING USED.



AVOID HITTING SLIDERS AGAINST STEEL PARTS, TOOLS, ETC., AS THIS MAY PERMANENTLY DAMAGE THE SLIDER (SURFACE DAMAGE OR BENDING.) DO NOT SAW, TURN, DRILL OR CUT OFF THE SLIDERS BECAUSE THIS WILL DESTROY THE SLIDERS AND MAY LEAD TO INFLAMMABLE DUST.

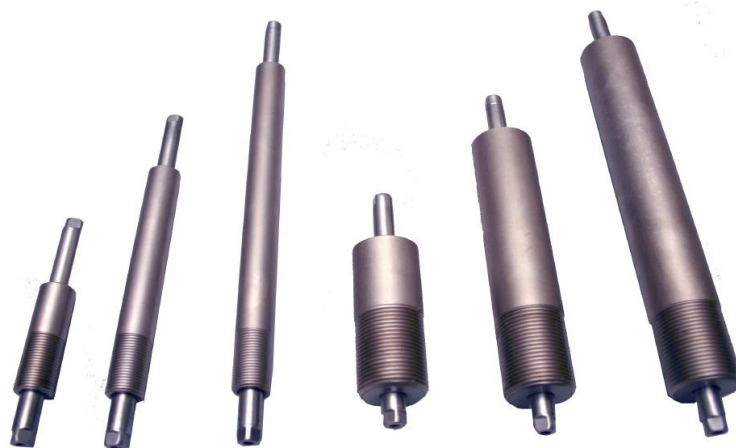

Table of contents

Table of contents	2
Mounting	3
Placing the slider into the stator	3
Attaching the load	3
Mounting MagSpring® Stators	4
Hint for proper mounting of Payload (adjustment of an angle offset)	4
Mounting of Payload with play-bushing	4
Maintenance of MagSpring®	5
Maintenance schedule for first applications / arduous environment	5
Lubricating instructions	5
Storage / transportation	5
Accessories	8
MagSpring® Flange MF01-20/H23 Part-No 0250-2306	8
MagSpring® Adapter MA01-20/H23 Part-No 0250-0116	8
MagSpring® Flange MF01-37/H37 Part-No 0250-2307	9
Installation Instructions:	9
MagSpring® Adapter MA01-37/H37 Part-No 0250-0117	9
Mounting of the magnetic spring MagSpring® to H-Guide	10
Declaration of Conformity CE-Marking	11
Contact Addresses	12



Introduction

Typical applications for the *MagSpring®* include:

- Counter balancing payload so that small Linear Motors can be used, particularly in vertical applications
- Retracting motor and load in the event of a power loss or E-stop condition
- Assisting Linear Motor in applications that require high force in one direction and lower force in the other by using motor to load spring while moving (returning) in low force requirement direction.

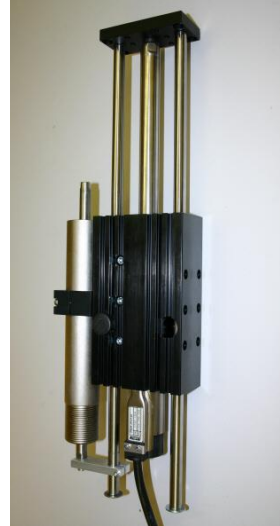

The mounting position of the *MagSpring®*, with respect to the H- Guide, determines the direction of the movement in which the *MagSpring®* is providing assistance. The exact placement of the *MagSpring®* on the H-Guide is defined by the stroke range of the combined *MagSpring®* / 'H-Guide / MPC assembly.

Mounting

Placing the slider into the stator

1. The force class of the slider is written on one end of the slider (e.g. the description 'M102033-20' means serial no M102033 / force class 20). Normally the slider end with the description is opposite the payload
2. Clean the slider with disposable paper.
3. Lubricate the slider as noted in 'Maintenance of MagSpring®' section).
4. Enter the slider as in photo exactly longitudinally to the stator (**attention: slider will be sucked into the stator and may shoot out on the opposite end of the stator**).
5. The SP distance (Start Position see data sheet) is calculated from the 'slider end without description' to the front end of the stator (stator end with thread).



Attaching the load

The load must be mounted only to the end of the slider facing the load mass using a suitable open-end wrench (beware there will be magnetic attraction between wrench and slider). Under no circumstances may the slider tube or the back end of the slider be used as "clamping piece".

Mounting MagSpring® Stators

MagSpring® Stators can be mounted either by using the thread on the barrel of the Stator or by using a MF01-xx mounting flange. When using the mounting flange be aware that over tightening may damage the stator.

Hint for proper mounting of Payload (adjustment of an angle offset)

Fixed End Washer Set PLF01-12 (Part-No 0150-3085) consisting of two pair of ball and socket washers, allows adjustment of an angle offset. The adjustment in the x- and y- direction is done by using an oversized hole for the mounting plate screw.

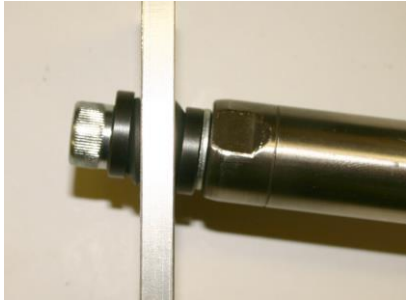
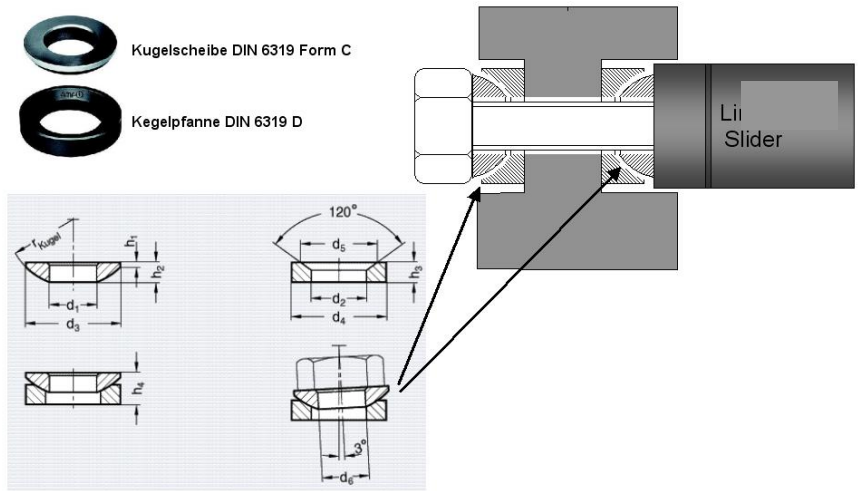

Function: Ball and socket washers adjust for angular offset between linear motor slider and Payload. (A spring washer should be used as well.)

Screw	d ₁	d ₂	d ₃	d ₄	d ₅	h ₁	h ₂	h ₃	h ₄	
M5	5,2 mm (0,20 in)	6,0 mm (0,24 in)	10,5 mm (0,41 in)	10,5 mm (0,41 in)	9,5 mm (0,37 in)	0,5 mm (0,02 in)	2,0 mm (0,08 in)	2,1 mm (0,08 in)	3,2 mm (0,13 in)	

Material: Hardened steel

Mounting of Payload with play-bushing

Play-bushing to handle alignment

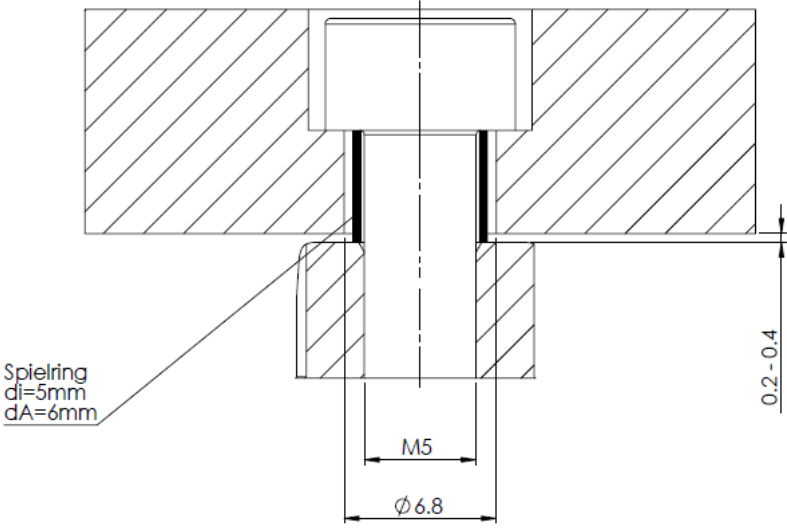

Maintenance of MagSpring®

The maintenance schedule below is based on a 5-day week with 8 working hours daily. Normal plant industrial operating conditions are assumed. Where conditions differ, such as with severe and/or dirty environments, direct sunshine, operation outside etc., the maintenance intervals must be shortened until empirical values for the particular application are obtained. Accordingly a distinction is drawn between the maintenance schedules for standard applications and first time applications or arduous conditions.

Maintenance schedule for standard applications

	Less than 120 strokes/min	120 to 360 strokes/min	Over 360 strokes/min
Commissioning	Inspection and lubrication	Inspection and lubrication	Inspection and lubrication
Every 3 months	--	Inspection	Inspection and lubrication
Every 6 months	Inspection	Inspection and lubrication	Inspection and lubrication

Maintenance schedule for first applications / arduous environment

	Less than 120 strokes/min	120 to 360 strokes/min	Over 360 strokes/min
Commissioning	Inspection and lubrication	Inspection and lubrication	Inspection and lubrication
After the first 8 hours	Inspection	Inspection	Inspection
After the first week' operation	Inspection	Inspection	Inspection
Every 3 months	Inspection	Inspection	Inspection and lubrication
Every 6 month s	Inspection and lubrication	Inspection and lubrication	Inspection and lubrication

Inspection

The following must be checked when inspecting the drives: 1.) Slider is lubricated completely 2.) Lubricant is not dried out 3.) Slider moves freely?

Cleaning

Do not use stiff brushes for cleaning. No cleaning fluids containing solvents, kerosene or similar are to be used: Carefully withdraw the slider from the stator. Clean the slider and stator with soft disposable paper, assisted by methylated spirit or alcohol possibly. Lubricate the slider and replace it carefully

Lubricating instructions

The lubricant reduces the friction between the chromium-nickel steel surface of the slider and the plastic sleeve bearing (POM or Delrin-based). In addition it prevents (fretting) corrosion. Important also is that it should retain low viscosity at low temperatures, and still not evaporate over time.

We recommend that the following lubricant be used (this Lubricant corresponds to KLÜBERSYNTH UH1 14-31 which was developed especially for the food processing industry):

Art. No.	0150-1953	(8g)
Art. No.	0150-1954	(50g)
Art. No.	0150-1955	(1000g)

Storage / transportation

- Sliders are to be stored and transported only in the provided shipping containers unless placed in MagSpring® stators.
- Maximum storage temperature: -40° ...+60 °C

Mechanical dimensions of the stators MS01-20

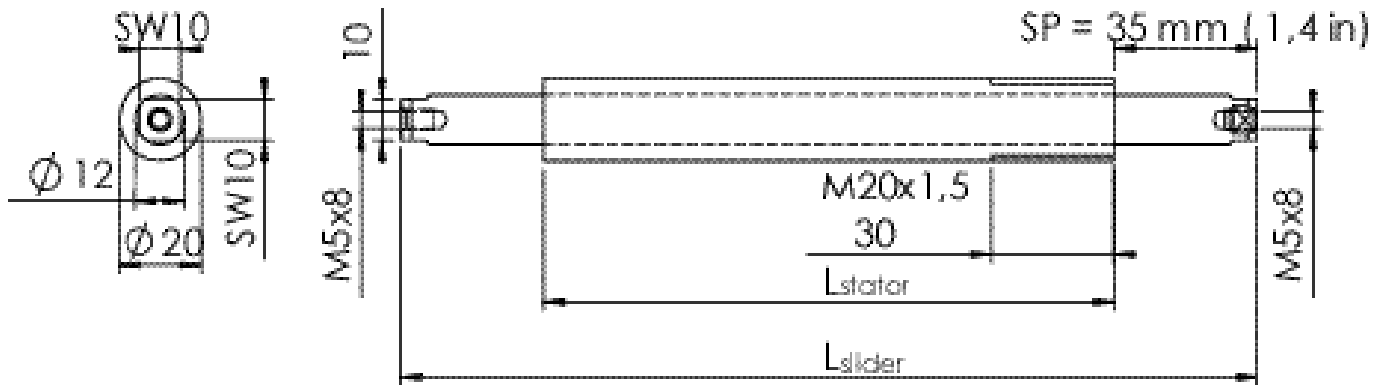

Stator	Part-Nr	Länge L _{Stator}	Durchmesser	Masse
MS01-20x60	0250-2200	60 mm [+/-0.3] (2.36 in)	20 mm (0.787 in)	75 g (0.16 lb)
MS01-20x140	0250-2201	140 mm [+/-0.3] (5.51 in)	20 mm (0.787 in)	180 g (0.37 lb)
MS01-20x220	0250-2202	220 mm [+/-0.3] (8.66 in)	20 mm (0.787 in)	285 g (0.58 lb)
MS01-20x300	0250-2207	300 mm [+/-0.3] (11.81 in)	20 mm (0.787 in)	389 g (0.8 lb)

Materials: Stator casing: Steel with Ni plating
bearing: based on POM (Delrin®)

Mechanical dimensions of the stators MS01-37

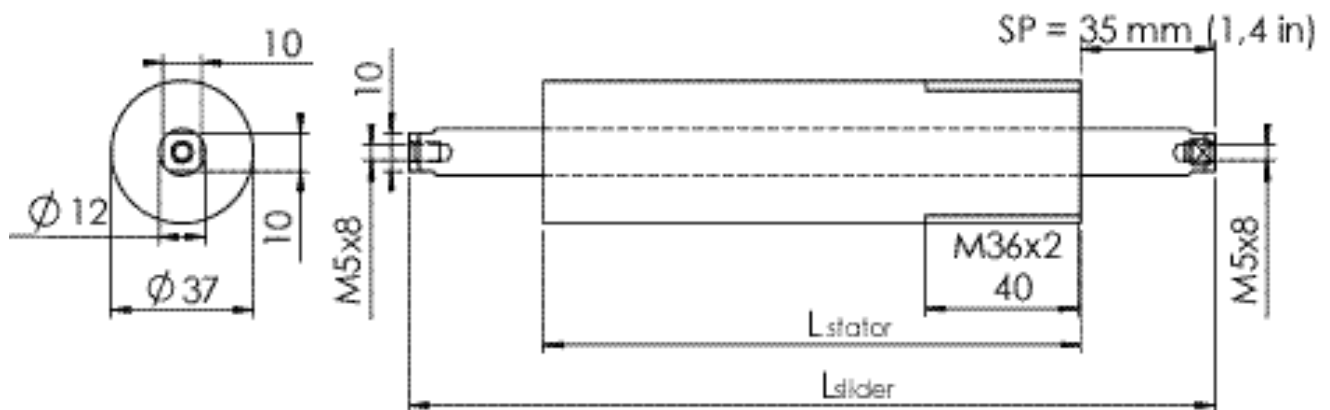

Stator	Part-Nr	Länge L _{Stator}	Durchmesser	Masse
MS01-37x80	0250-2203	80 mm [+1/-0.2] (3.15 in)	37 mm (1.46 in)	440g (0.90 lb)
MS01-37x155	0250-2204	155 mm [+1/-0.2] (6.10 in)	37 mm (1.46 in)	880 g (1.8 lb)
MS01-37x230	0250-2205	230 mm [+1/-0.2] (9.05 in)	37 mm (1.46 in)	1320 g (2.7 lb)
MS01-37x305	0250-2206	305 mm [+1/-0.2] (12.0 in)	37 mm (1.46 in)	1750 g (3.6 lb)
MS01-37x380	0250-2209	380 mm [+1/-0.2] (14.9 in)	37 mm (1.46 in)	2180 g (4.5 lb)

Materials: Stator casing: Steel with Ni plating
bearing: based on POM (Delrin®)

The stators can be mounted by the thread or by clamping.

Slider	Part-Nr	Length L _{Slider}	Diameter	Mass	Thread
ML01-12x130/80-10	0250-2300	130 mm (5.12 in)	12 mm (0.47 in)	ca 75 g (0.16 lb)	M5
ML01-12x130/80-15	0250-2308	130 mm (5.12 in)	12 mm (0.47 in)	ca 75 g (0.16 lb)	M5
ML01-12x130/80-20	0250-2301	130 mm (5.12 in)	12 mm (0.47 in)	ca 75 g (0.16 lb)	M5
ML01-12x210/160-10	0250-2302	210 mm (8.27 in)	12 mm (0.47 in)	ca 155 g (0.30 lb)	M5
ML01-12x210/160-15	0250-2309	210 mm (8.27 in)	12 mm (0.47 in)	ca 155 g (0.30 lb)	M5
ML01-12x210/160-20	0250-2303	210 mm (8.27 in)	12 mm (0.47 in)	ca 155 g (0.30 lb)	M5
ML01-12x290/240-10	0250-2304	290 mm (11.42 in)	12 mm (0.47 in)	ca 220 g (0.45 lb)	M5
ML01-12x290/240-15	0250-2310	290 mm (11.42 in)	12 mm (0.47 in)	ca 220 g (0.45 lb)	M5
ML01-12x290/240-20	0250-2305	290 mm (11.42 in)	12 mm (0.47 in)	ca 220 g (0.45 lb)	M5
ML01-12x370/240-10	0250-2311	370 mm (14.56 in)	12 mm (0.47 in)	ca 280 g (0.57 lb)	M5
ML01-12x370/240-15	0250-2312	370 mm (14.56 in)	12 mm (0.47 in)	ca 280 g (0.57 lb)	M5
ML01-12x370/240-20	0250-2313	370 mm (14.56 in)	12 mm (0.47 in)	ca 280 g (0.57 lb)	M5

Materials: stainless steel 1.4301

Ordering information

Force	Stroke	MagSpring®	Stator		Slider	
			Description	Part-Nr	Description	Part-Nr
11 N	50 mm (1,97in)	M01-20x60/50x11N	MS01-20x60	0250-2200	ML01-12x130/80-10	0250-2300
11 N	130 mm (5,1 in)	M01-20x140/130x11N	MS01-20x140	0250-2201	ML01-12x210/160-10	0250-2302
11 N	210 mm (8.3 in)	M01-20x220/210x11N	MS01-20x220	0250-2202	ML01-12x290/240-10	0250-2304
11 N	290 mm (11.8in)	M01-20x300/290x11N	MS01-20x300	0250-2207	ML01-12x370/240-10	0250-2311
17 N	50 mm (1,97in)	M01-20x60/50x17N	MS01-20x60	0250-2200	ML01-12x130/80-15	0250-2308
17 N	130 mm (5,1 in)	M01-20x140/130x17N	MS01-20x140	0250-2201	ML01-12x210/160-15	0250-2309
17 N	210 mm (8.3 in)	M01-20x220/210x17N	MS01-20x220	0250-2202	ML01-12x290/240-15	0250-2310
17 N	290 mm (11.8in)	M01-20x300/290x17N	MS01-20x300	0250-2207	ML01-12x370/240-15	0250-2312
22 N	50 mm (1.97 in)	M01-20x60/50x22N	MS01-20x60	0250-2200	ML01-12x130/80-20	0250-2301
22 N	130 mm (5,1 in)	M01-20x140/130x22N	MS01-20x140	0250-2201	ML01-12x210/160-20	0250-2303
22 N	210 mm (8.3 in)	M01-20x220/210x22N	MS01-20x220	0250-2202	ML01-12x290/240-20	0250-2305
22 N	290 mm (11.8in)	M01-20x300/290x22N	MS01-20x300	0250-2207	ML01-12x370/240-20	0250-2313
40 N	50 mm (1.97 in)	M01-37x80/50x40N	MS01-37x80	0250-2203	ML01-12x130/80-10	0250-2300
40 N	125 mm (4.92 in)	M01-37x155/125x40N	MS01-37x155	0250-2204	ML01-12x210/160-10	0250-2302
40 N	200 mm (7.87 in)	M01-37x230/200x40N	MS01-37x230	0250-2205	ML01-12x290/240-10	0250-2304
40 N	275 mm (10.8 in)	M01-37x305/275x40N	MS01-37x305	0250-2206	ML01-12x370/240-10	0250-2311
50 N	50 mm (1.97 in)	M01-37x80/50x50N	MS01-37x80	0250-2203	ML01-12x130/80-15	0250-2308
50 N	125 mm (4.92 in)	M01-37x155/125x50N	MS01-37x155	0250-2204	ML01-12x210/160-15	0250-2309
50 N	200 mm (7.87 in)	M01-37x230/200x50N	MS01-37x230	0250-2205	ML01-12x290/240-15	0250-2310
50 N	275 mm (10.8 in)	M01-37x305/275x50N	MS01-37x305	0250-2206	ML01-12x370/240-15	0250-2312
60 N	50 mm (1.97 in)	M01-37x80/50x60N	MS01-37x80	0250-2203	ML01-12x130/80-20	0250-2301
60 N	125 mm (4.92 in)	M01-37x155/125x60N	MS01-37x155	0250-2204	ML01-12x210/160-20	0250-2303
60 N	200 mm (7.87 in)	M01-37x230/200x60N	MS01-37x230	0250-2205	ML01-12x290/240-20	0250-2305
60 N	275 mm (10.8 in)	M01-37x305/275x60N	MS01-37x305	0250-2206	ML01-12x370/240-20	0250-2313

* nominal force +/- 15% at 20°C 1 N = 0.2248 lb

Accessories

MagSpring® Flange MF01-20/H23 Part-No 0250-2306

Installation Instructions:

1. Install mounting flange with two M4 mounting screws. Do not tighten at this time.
2. Position MagSpring® in flange and tighten clamping screw - Max torque: 200 Ncm (1.475 ft lbs.) Over tightening may damage the MagSpring.
3. Tighten mounting screws.

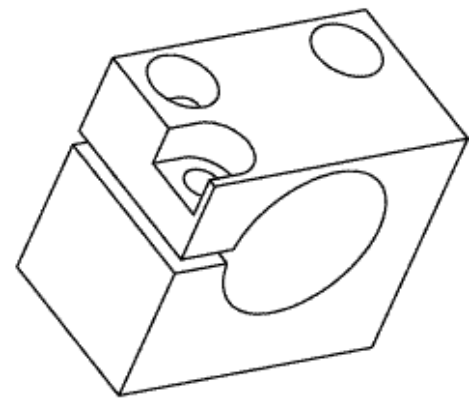
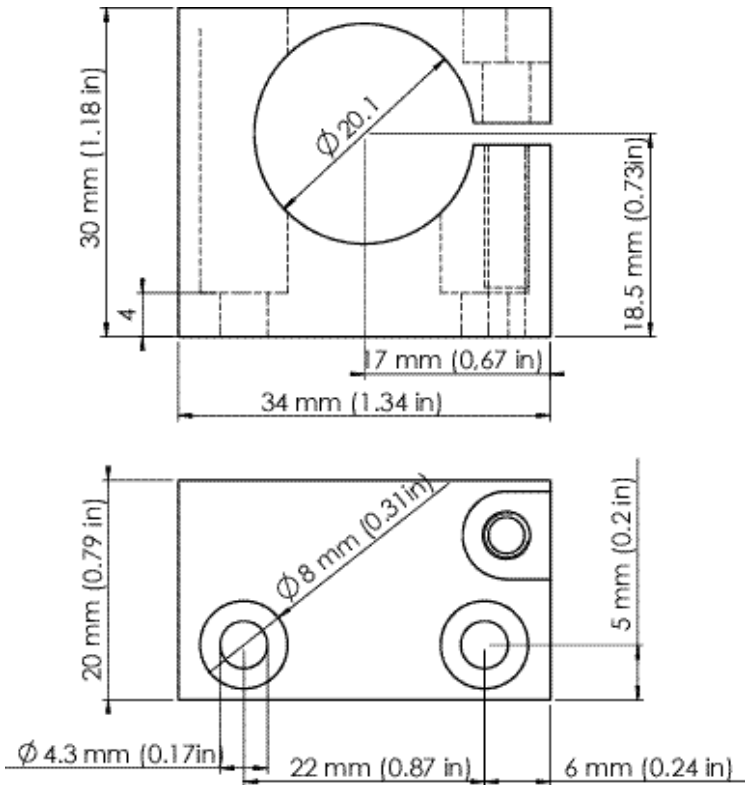

Material: Aluminium (AlMgSi)
Black anodized
Weight: ca 30 g (0.066 lb)
Clamping screw: M4x16 screw ISO 4762 (1)
Mounting screws: M4x10 screw ISO 4762 with rectangular nuts (for H-Guide) (2)
Spring washer: M4 (Din 128 A) (3)

Part-No: 0250-2306 MF01-20/H23

MagSpring® Adapter MA01-20/H23 Part-No 0250-0116

Adapter between MagSpring® MS01-20 and H-Guide H01-23x..

Material: Aluminium (AlMgSi)
Black anodized
Weight: ca 18 g (0.034 lb)
Clamping screw: M3x18 screw ISO 4762 (1)
Mounting screws: M5x14 screw ISO 4762 (1)
Disc Spring washer: DIN 2093A 10/5,2/0,5 (1)

Part-No: 0250-0116 MA01-20/H23

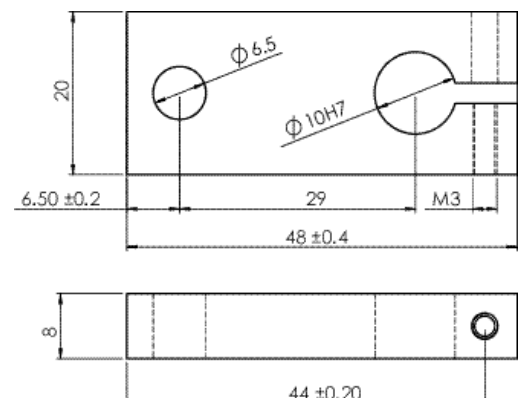

Assembling MagSpring®



MagSpring® Flange MF01-37/H37 Part-No 0250-2307

Installation Instructions:

1. Install mounting flange with two M4 mounting screws. Do not tighten at this time.
2. Position MagSpring® in flange and tighten clamping screw - Max torque: 200 Ncm (1.475 ft lbs.) Over tightening may damage the MagSpring®. Align MagSpring® with H-Guide rods
3. Tighten mounting Flange screws (Note: with M01-37 MagSprings® it will be necessary to remove MagSpring® from the mounting bracket in order to tighten mounting Flange screws.

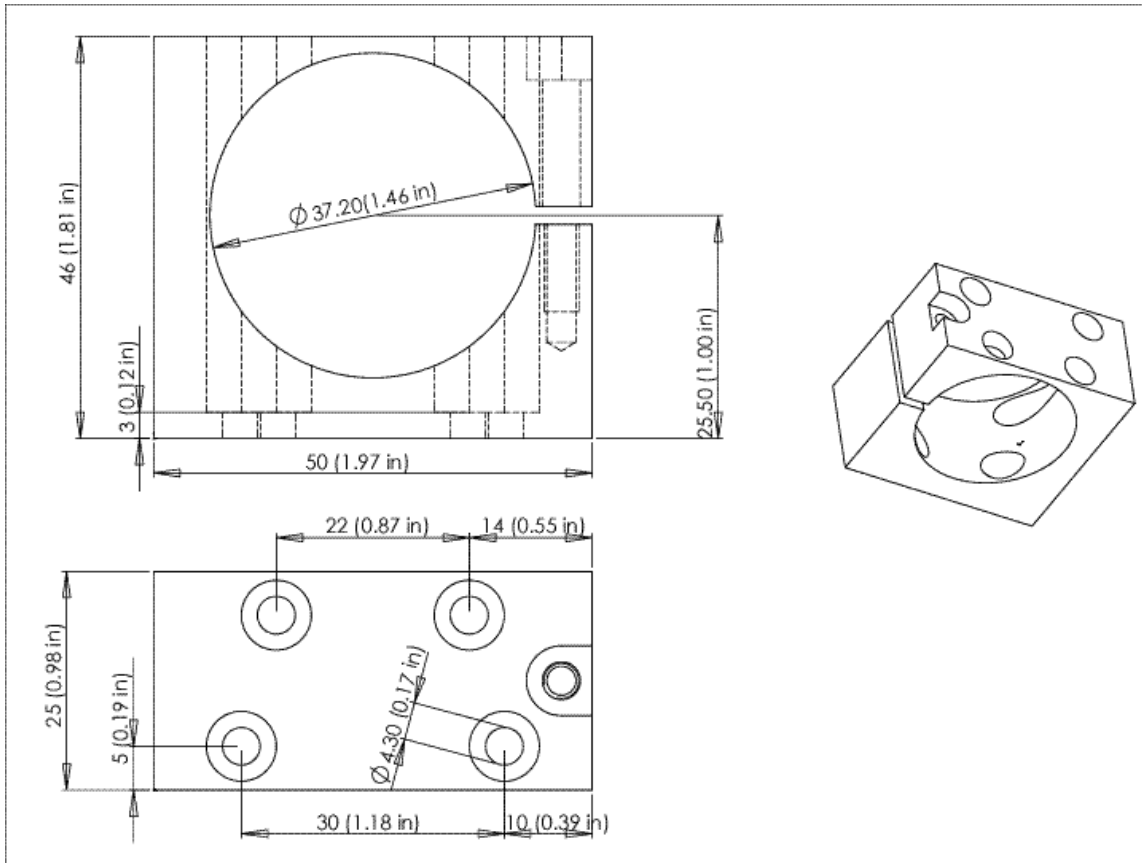

all dimensions in mm / () denotes inch

- Material: Aluminium (AlMgSi)
Black anodized
- Weight: ca 70 g (0.15 lb)
- Clamping screw: M4x25 screw ISO 4762 (1)
- Mounting screws: M4x10 screw ISO 4762 (with rectangular nut for H-Guide) (2)
- Spring washer: M4 (Din 128 A) (3)
- Part-No: 0250-2307 MF01-37/H37







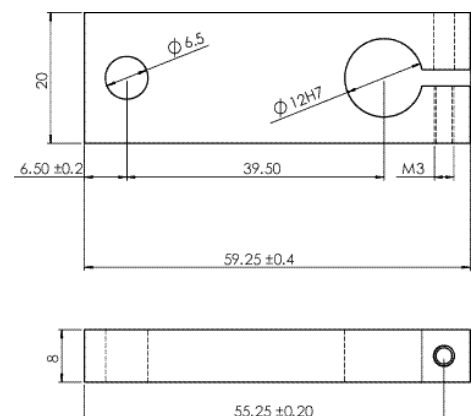



MagSpring® Adapter MA01-37/H37 Part-No 0250-0117

Adapter between MagSpring®MS01-37 and H-Guide H01-37x..

- Material: Aluminium (AlMgSi)
Black anodized
- Weight: ca 18 g (0.034 lb)
- Clamping screw: M3x18 screw ISO 4762 (1)
- Mounting screws: M5x14 screw ISO 4762 (1)
- Disc Spring washer: DIN 2093A 10/5,2/0,5 (1)
- Part-No: 0250-0117 MA01-37/H37



Mounting of the magnetic spring MagSpring® to H-Guide

<p>1a</p>	 <p>Parts: H-Guide Assembly, <i>MagSpring®</i>, Mounting Flange, Coupling, Misc. Hardware</p>	<p>1b</p>	 <p>Pre-assemble mounting screws and rectangular nuts on to mounting Flange.</p>
<p>1c</p>	 <p>Place Flange on H-Guide with rectangular nuts in 'T'-slot of H-Guide.</p>	<p>1d</p>	 <p>Tighten mounting Flange screws only enough to make mounting Flange 'snug' on H-Guide</p>
<p>1e</p>	 <p>Insert <i>MagSpring™</i> into mounting Flange and lightly tighten clamping screw</p>	<p>1f</p>	 <p>Align <i>MagSpring®</i> with H-Guide rods. Note: Axis of <i>MagSpring®</i> must be absolutely parallel to rods of H-Guide</p>
<p>1g</p>	 <p>Tighten mounting Flange screws (Note: with M01-37 <i>MagSprings®</i> it will be necessary to remove <i>MagSpring®</i> from the mounting bracket in order to tighten mounting Flange screws – replace <i>MagSpring®</i>)</p>	<p>1h</p>	 <p>Move <i>MagSpring®</i> to desired position and tighten clamping screw (200 Ncm (1.41 ft lbs).</p>
<p>1i</p>	 <p>Attach Adapter to end of <i>MagSpring®</i> and to H-Guide rod. Use Disc Spring washer between <i>MagSpring Slider</i> and Adapter 2093A 10/5,2/0,5 (1)</p>	<p>1j</p>	 <p>Check Alignment – all parts must move freely. If tight spots or resistance to free movement is noted, realign as necessary</p>

Declaration of Conformity CE-Marking

Manufacturer: NTI AG
Haerdlistrasse 15
8957 Spreitenbach
Switzerland
Tel.: +41 (0) 56 419 91 91
Fax: +41 (0) 56 419 91 92

Products: *MagSpring*® Magnetic Springs

Type	Art.-No.	Type	Art.-No.
ML01-12x130/80-10	0250-2300	MS01-20x60	0250-2200
ML01-12x130/80-15	0250-2308	MS01-20x140	0250-2201
ML01-12x130/80-20	0250-2301	MS01-20x220	0250-2202
		MS01-20x300	0250-2207
ML01-12x210/160-10	0250-2302		
ML01-12x210/160-15	0250-2309	MS01-37x80	0250-2203
ML01-12x210/160-20	0250-2303	MS01-37x155	0250-2204
		MS01-37x230	0250-2205
ML01-12x290/240-10	0250-2304	MS01-37x305	0250-2206
ML01-12x290/240-15	0250-2310	MS01-37x380	0250-2209
ML01-12x290/240-20	0250-2305	MS01-37x680	0250-2211
ML01-12x370/240-10	0250-2311		
ML01-12x370/240-15	0250-2312		
ML01-12x370/240-20	0250-2313		
ML01-12x335/240-20	0250-2320		
ML01-12x350/240-10	0250-2333		
ML01-12x350/240-20	0250-2321		
ML01-12x450/400-20	0250-2332		
ML01-12x690/640-20	0250-2325		
ML01-12x xxx/xxx-xx-cust	div		

The product must be mounted and used in strict accordance with the installation instruction contained within the User's Manual, a copy of which may be obtained from NTI AG.

I declare that as the authorized representative, the above information in relation to the supply/manufacture of this product is in conformity with the stated standards and other related documents in compliance with the protection requirements of the EMC Directive (89/336/EEC) and is marked in accordance with the CE Marking Directive (93/68/EEC).

Company
NTI AG

Spreitenbach, Dez, 2005



Dr.-Ing. Ronald Rohner / CEO NTI AG

Contact Addresses

NTI AG

Haerdlistrasse 15	Tel.:	+41 (0)56-419 91 91
CH-8957 Spreitenbach	Fax:	+41 (0)56-419 91 92
Switzerland	E-Mail:	office@linmot.com
	Web:	www.linmot.com

LinMot USA Inc.

204 E Morrissey Dr.	Sales:	877-546-3270
Elkhorn		262-743-2555
WI 53121	Tech. Service:	877-804-0718
USA		262-743-1284
	Fax:	800-463-8708
		262-723-6688
	E-Mail:	usasales@linmot.com
	Web:	www.linmot-usa.com

NTI AG (as a manufacturer or LinMot and MagSpring products) is not responsible for any damages caused by improper use, application, or handling of NTI AG manufactured or supplied materials and is not responsible for any consequential damages of any sort relating to the use of LinMot or MagSpring products.

NTI AG's warranty is limited to repair or replacement as stated in our standard warranty policy as described in our "terms and conditions" previously supplied to the purchaser of our equipment (please request copy of same if not otherwise available). Product warranties are void if products are used with stators, sliders, or controllers not manufactured by NTI AG unless such use was specifically approved by NTI AG.

A copy of this notice must be attached to each motor and/or machine that the purchaser provides to others.

LinMot® and MagSpring® are registered trademarks of NTI AG

Specification of products are subject to change without notification